

# FingerPrint Door Lock

## BioAxxis® L113 (Stand-Alone) Installation Manual (for cylindrical latchset)



**BioAxxis** Axxis Biometrics, LLC

**Revision 0.81 / Dec 2005**

Address: 15 East Genesee Street, Suite 270, Baldwinsville, NY, USA 13027  
Telephone: 315-635-5540 Fax: 315-635-5539



# TABLE OF CONTENTS

---

## 1) INTRODUCTION

- 1.1 □ Description of Main Parts ----- 2
- 1.2 □ Description of Latchset ----- 3

## 2) HOW TO INSTALL

### 2.1) Drilling Holes on Door & Door Frame

- 2.1.1) Holes on Door ----- 4-5
- 2.1.2) Holes on Door Frame ----- 6

### 2.2) Installing Cylindrical Latchset

- 2.2.1) Installing Door Strike ----- 7
- 2.2.2) Installing Latchset Body ----- 7

### 2.3) Installing Fingerprint Entrance Set

- 2.3.1) Installing Front Case ----- 8
- 2.3.2) Select & Install Proper  
Transmission Shaft ----- 8-9
- 2.3.3) Installing Back Case ----- 10
- 2.3.4) Installing Battery Cover ----- 11

### 2.4) Caution in Installation ----- 11

### 2.5) Installing External DC Power

- 2.5.1) When to use External DC Power ----- 12
- 2.5.2) L101 ----- 12
- 2.5.3) L113 ----- 13

# 1) INTRODUCTION

## 1.1) Description of Main Parts

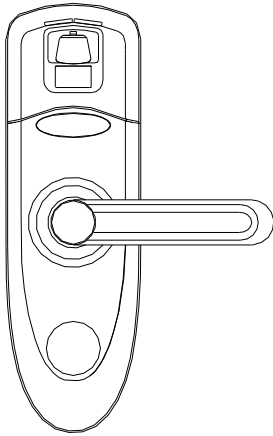

FRONT CASE (1x)

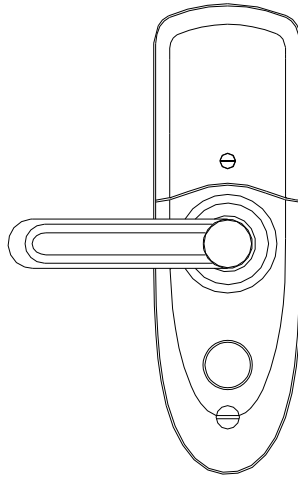

BACK CASE (1x)

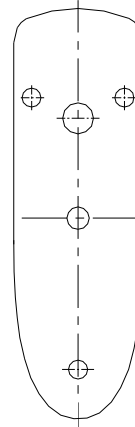

SILICONE WEATHER SEAL GASKET(1x)

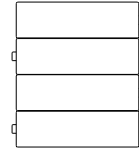

AA BATTERIES (4x)

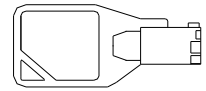

EMERGENCY KEY (2x)

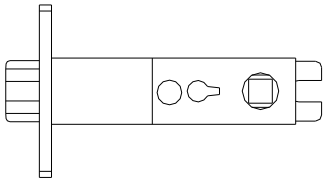

CYLINDRICAL LATCHSET (1x)

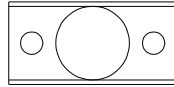

PLASTIC FACEPLATE (1x)

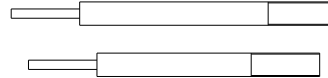

TRANSMISSION SHAFTS ( Short : 1x , Long : 1x )



Flat Head Phillips Screw  
M5 x 55mm (2 1/8") L (3x)  
M5 x 65mm (2 1/2") L (3x)

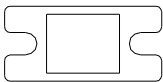

DOOR STRIKE HOLDER (1x)

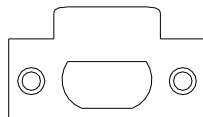

DOOR STRIKE (1x)



SMALL SPANNER WRENCH (2x)



Flat Head Phillips Wood Screw  
M4 x 20mm (3/4") L (4x)



LOCKING PIN (1x)



E-RING (1x)



LARGE SPANNER WRENCH (1x)

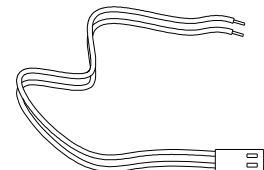

External DC Power Connection Cable (1x)

# 1.2) Description of adjustable backset (BS) Latchset

Plastic faceplate (1x)

E-Ring (1x)

Locking Pin(1x)

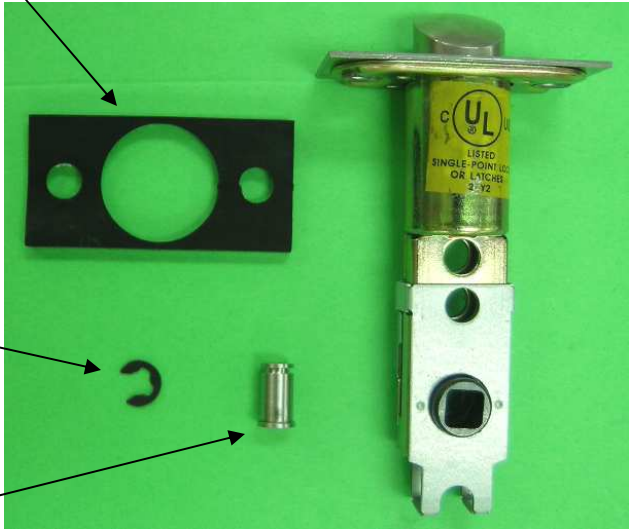

1'' faceplate width



C1 Latch: To adjust and lock the latch at 2 3/8'' BS position.

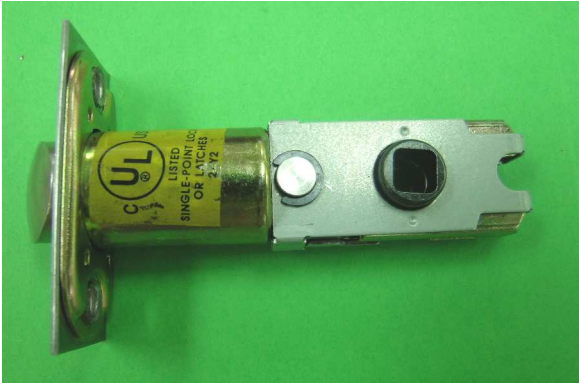

1 1/8'' faceplate width after adding the plastic faceplate



C2 Latch: To adjust and lock the latch at 2 3/4'' BS position.



Remark: The bevel of the latch bolt should face the door closing direction during installation of latch. Otherwise, turn it 180 deg. along the X-axis to get proper orientation.

## 2) HOW TO INSTALL

### 2.1) Drill Holes on Door & Door Frame

#### 2.1.1) Holes on Door

- a) User to define desired lock height L (measure from floor surface to center of door lever).
- b) Attach the template for door front, along the door edge, and adjust vertically to get the desired height .
- c) Then, attach another piece of template for the door edge. Match the latchset centerline with the lever centerline horizontally and align vertical centerline to the door edge center simultaneously.
- d) Drill and trim the holes to dimensions as shown.

#### Notes:

- Technique for drilling big size holes:

Drill a small pilot hole through the door to identify hole location . Then bore the required hole size half way from both sides of door to prevent chipout around holes when the boring tool breaks through.

- Always use the door edge for template alignment as shown on the full-size hole drilling template provided, in order to make sure that all lock housing mounting post through holes are correctly located for a 60mm (2-3/8"), or a 70mm (2-3/4") backset dimension from edge of door (see notes on template). This will prevent housing to latch assy alignment problems that can result if existing lock being replaced was not installed using standard backset dimensions.

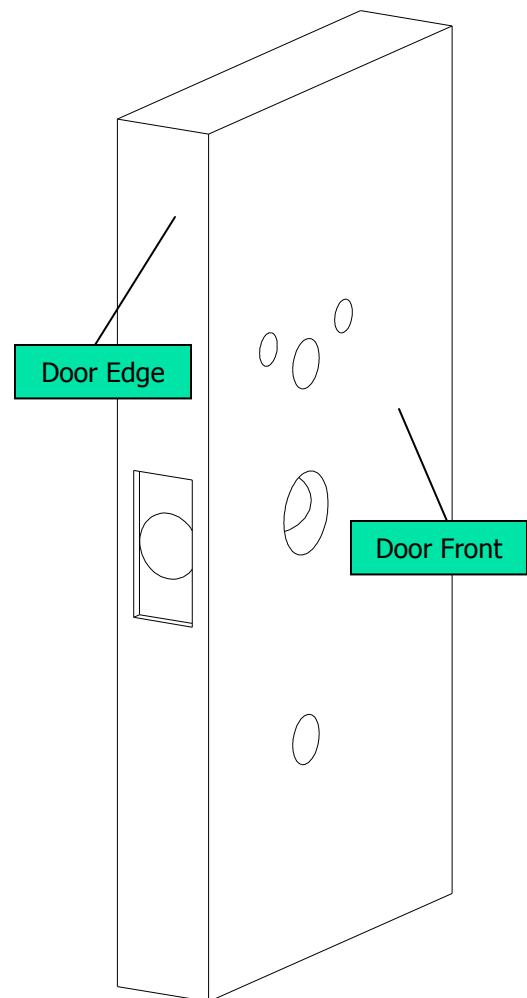

## Dimensions for Drilling/Trimming Holes

**Ref:** Below door preparation instructions are for installing the lock assembly in a new door. For a retro-fit installation, only (2) 1/2", and (2) 3/4" holes, are required for mounting the cases and latchset hardware. Trimming may be required to fit the door strike and latch faceplate. Also, the 1 1/4" dia hole (new door only), will be a standard 2 1/8" diameter hole, with a 2 3/8" (C1), or 2 3/4" (C2) backset from edge of door.

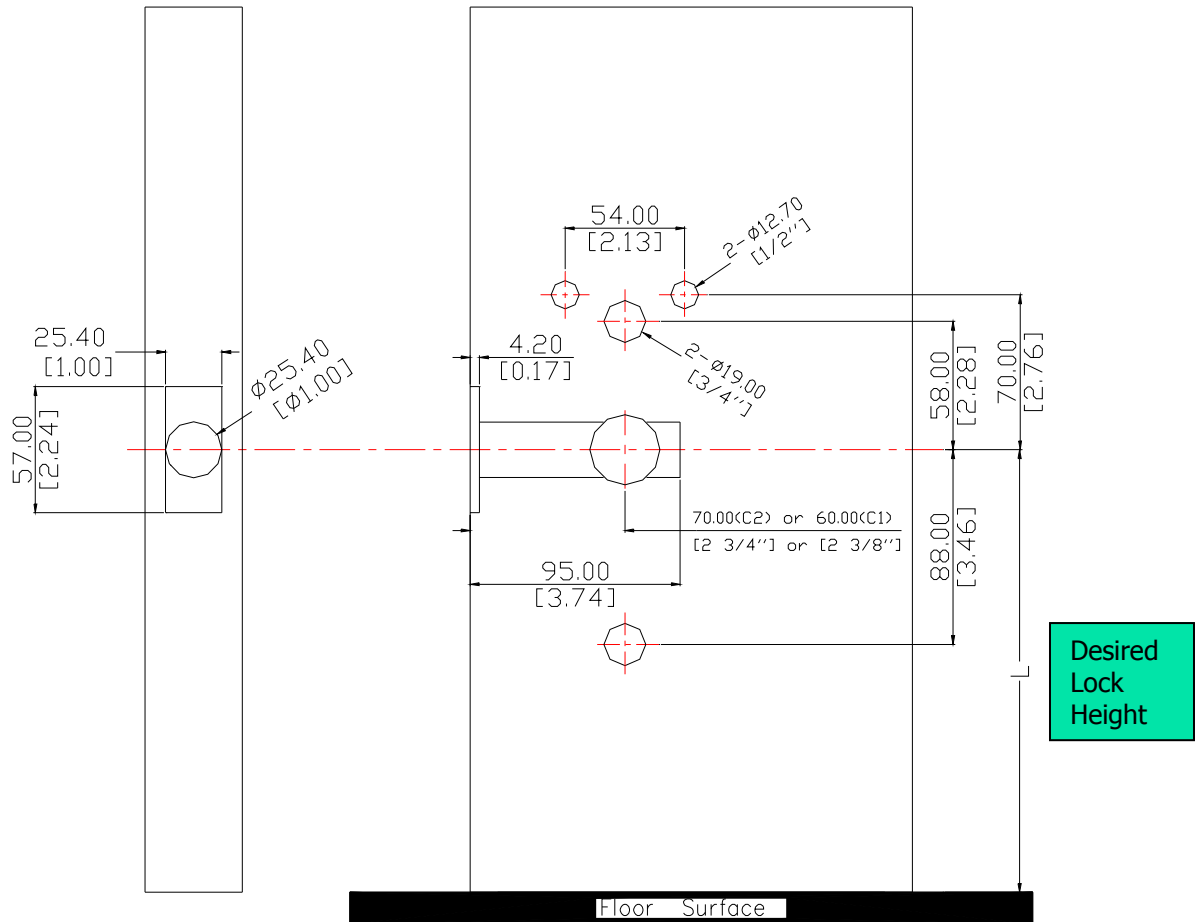

Unit in mm[inch]

### 2.1.2) Hole on Door Frame

- Extend the centerline of door lever (horizontal) to door frame when door is in closed condition (same desired height L).
- Then attach the template for the door strike.
- Match the door strike centerline with the lever centerline horizontally and align its vertical centerline to the door edge center simultaneously.
- Drill and trim the holes to dimensions as shown.

Remark: The template may need to be offset (left/right) a little to obtain optimum clearance between latch bolt and door strike.

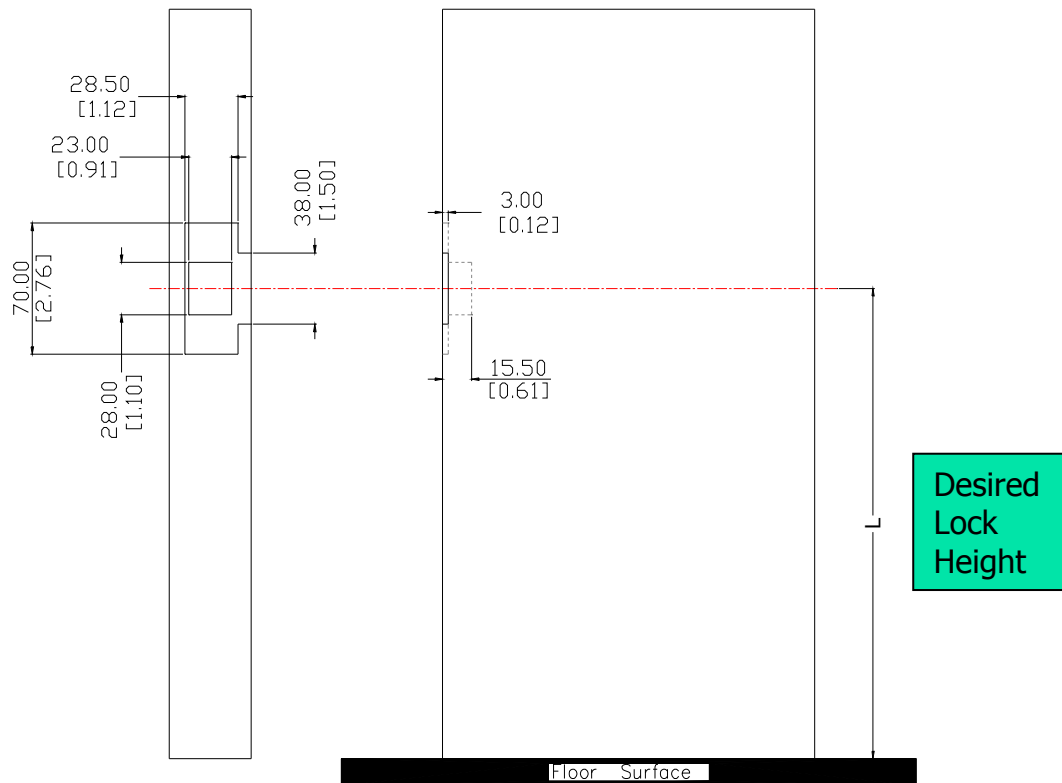
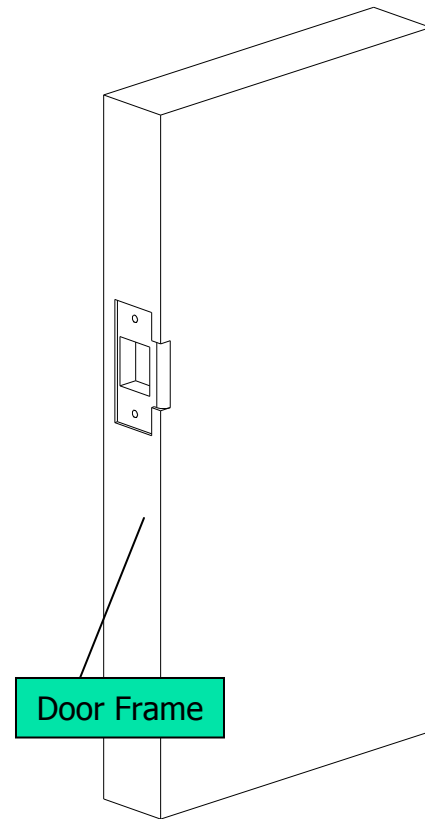

Unit in mm [inch]

## 2.2) Installing Cylindrical Latchset

### 2.2.1) Installing Door Strike

- a) Insert strike holder and door strike into the door frame in sequence as shown.
- b) Screw the door strike and door strike holder into its opening as shown.

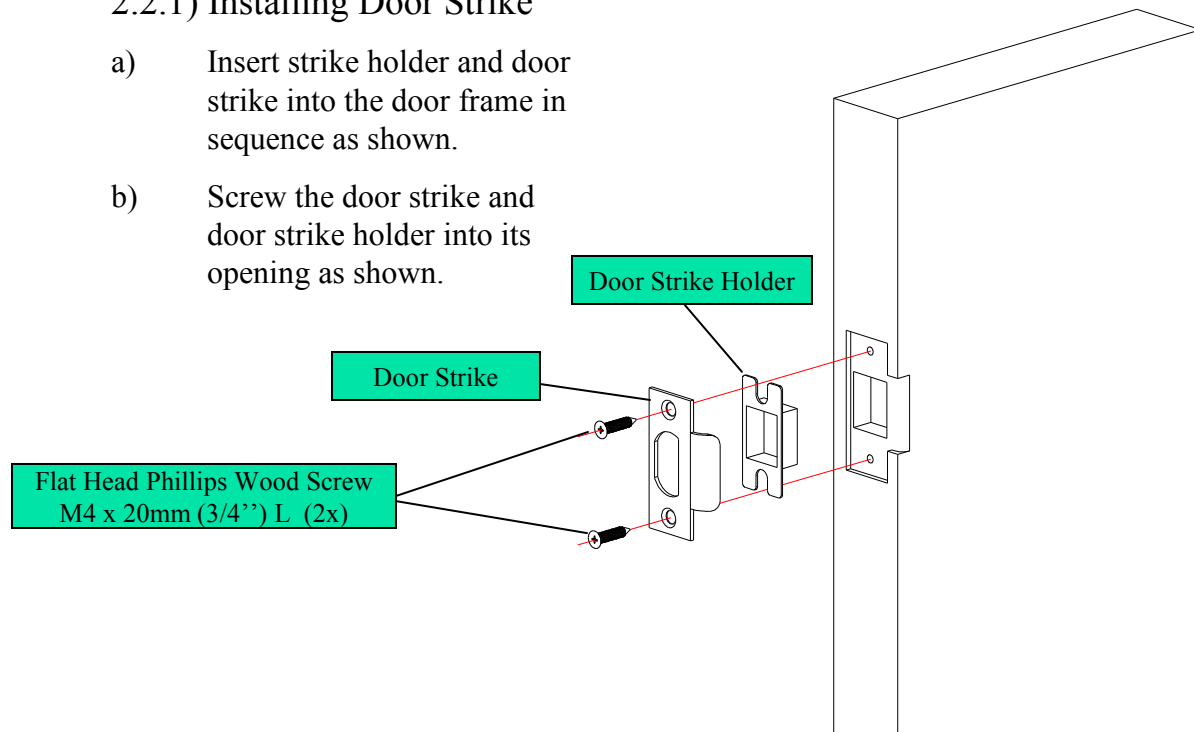

### 2.2.2) Installing Latchset Body

- a) Insert latchset to the door edge with its bevel side facing the door strike when closing the door.
- b) Screw Latchset into its opening as shown and test by pressing the latch bolt several times.

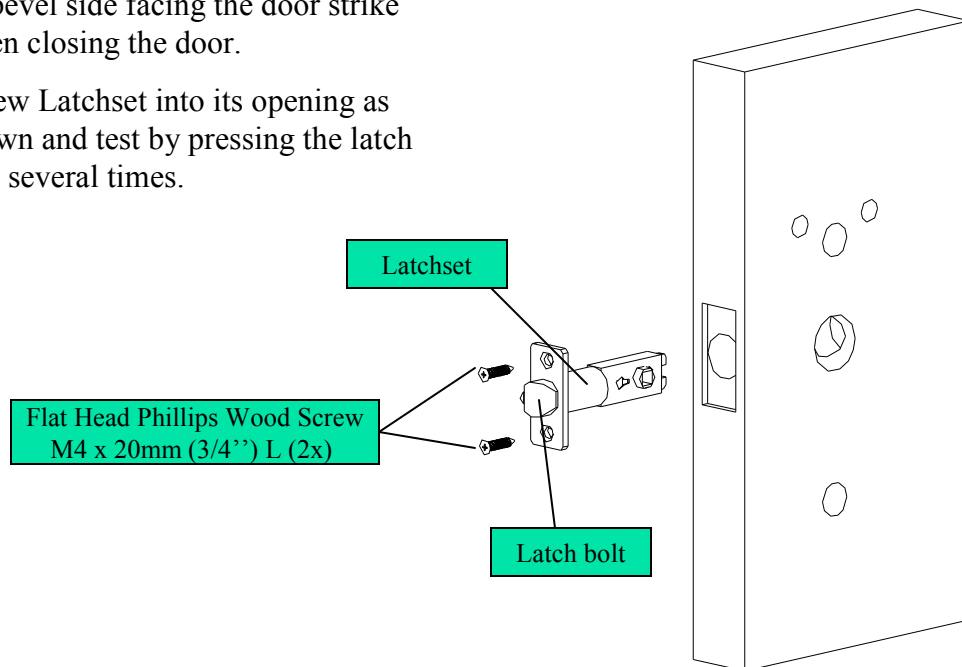

## 2.3) Installing Fingerprint Entrance Set

### 2.3.1) Install Front Case

- a) Position the silicone weather seal gasket on the back of the front case. (Optional for indoor installation)
- b) Put cables through the upper cable hole as shown.
- c) Then place front case onto the door, position the three extended posts through the mounting holes of the door as shown.
- d) Hold in position by hand temporarily until put together with the back case in next step.

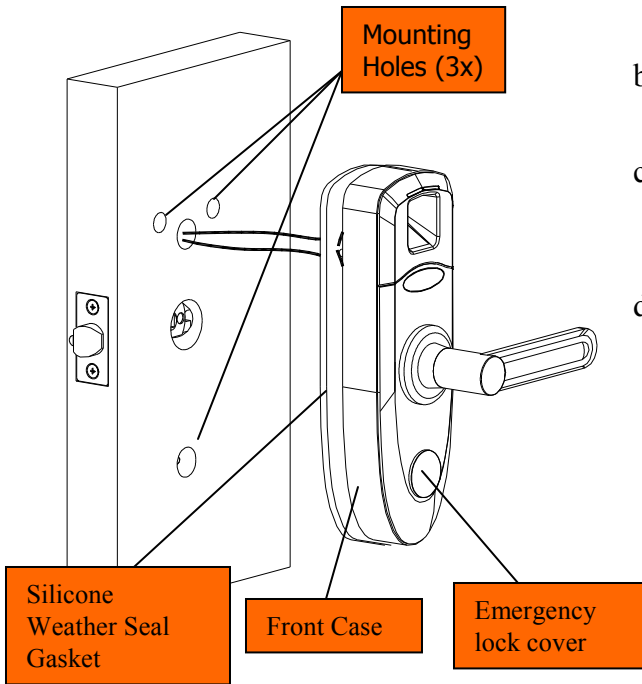

**Remark:**  
For a one-person installation, Use masking tape to hold the front case in position while working on the back case.

### 2.3.2) Select & Install Proper Transmission Shaft

- a) Select proper transmission shaft length based on door thickness.
- b) Follow the instructions indicated on next page as to the orientation of shaft used for different door opening directions. (refer page 9)
- c) Make sure the orientation of shaft is correct when inserting into the lock.
- d) Insert proper shaft through the latch, and let it go into the hole on the door lever of front case.

**Application of different length of shafts:**

- Short Shaft:  
For door thickness (35 - 45mm) or (1 3/8 - 1 3/4 inch)
- Long Shaft:  
For door thickness (46 - 57mm) or (1 3/4 - 2 1/4 inch)

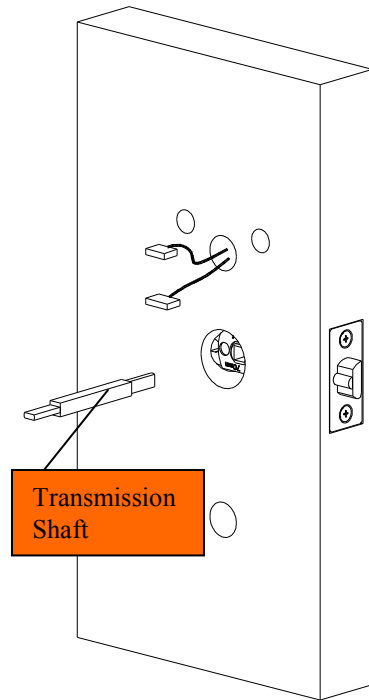

## For RH Type (Opening In & Out)

Note: Transmission Shaft must be rotated 90 degrees from that shown, if the notched shaft hole in the back handle as shown.

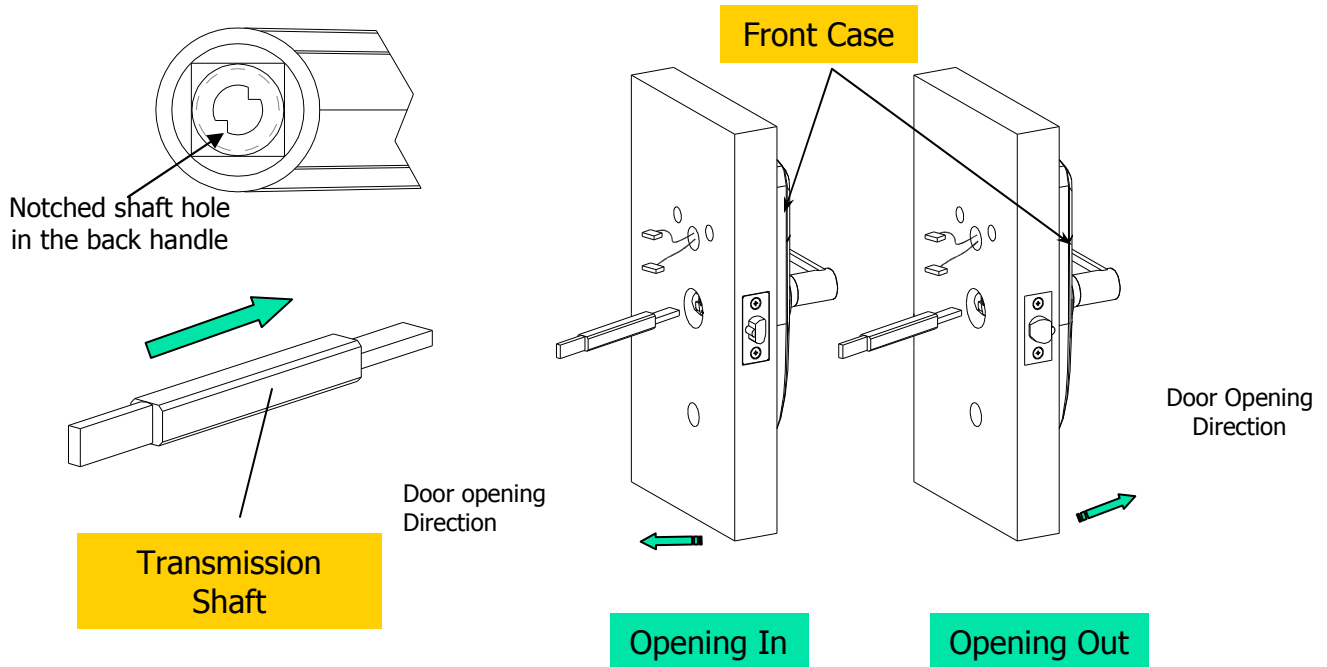

## For LH Type (Opening In & Out)

Note: Transmission Shaft must be rotated 90 degrees from that shown, if the notched shaft hole in the back handle as shown.

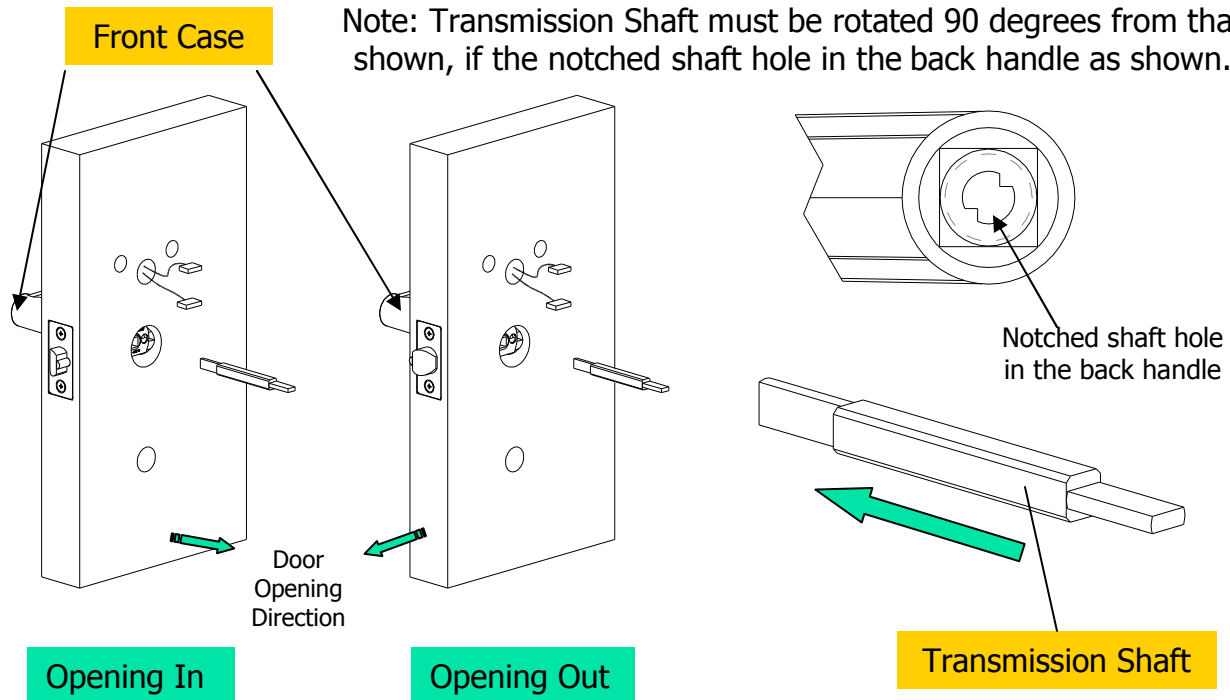

### 2.3.3) Installing Back Case

a) Preparation work before installation

- Use large spanner wrench to loosen the holding nut of the door lever by about 1-2 turns as shown.
- Remove battery cover after loosening the battery screw.
- Then remove cosmetic screw from the lowest end of the back case.

b) Connect the connectors to the sockets on PCBA.

- Blue 9 pin connector to Blue socket
- Red 10 pin connector to Red socket

Note: Make sure the connectors are aligned with sockets before pushing them into position to prevent bending of pins, or breakage of socket walls.

c) Put the back case to the door and let the transmission shaft passing through the hole of the door lever.

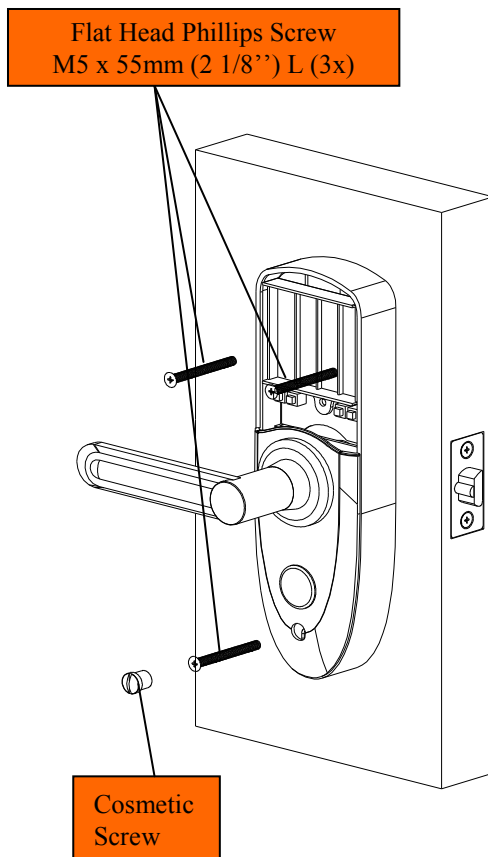
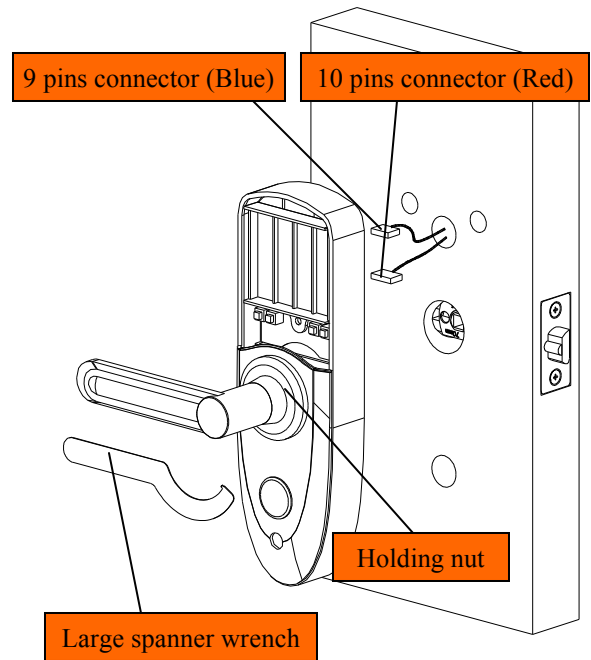

- e) Align the case to match with the three mounting holes.
- f) Use three mounting screws to slightly tighten and secure the Front & Back cases to the door.
- g) Hand tighten the holding nut of the door lever.
- h) Use screw driver to finish tightening the three mounting screws.
- i) Then use large spanner wrench to tighten the door lever.
- j) Be sure the door lever is working properly with no binding.
- k) Otherwise, loosen the three mounting screws a little and gently turn the lever several times before re-tightening the screws again.
- l) Then install and tighten the cosmetic screw with screwdriver.

### 2.3.4) Installing Battery Cover

- a) Install (4) AA batteries into battery holder as shown.
- b) Then replace battery cover and tighten cover holding screw.

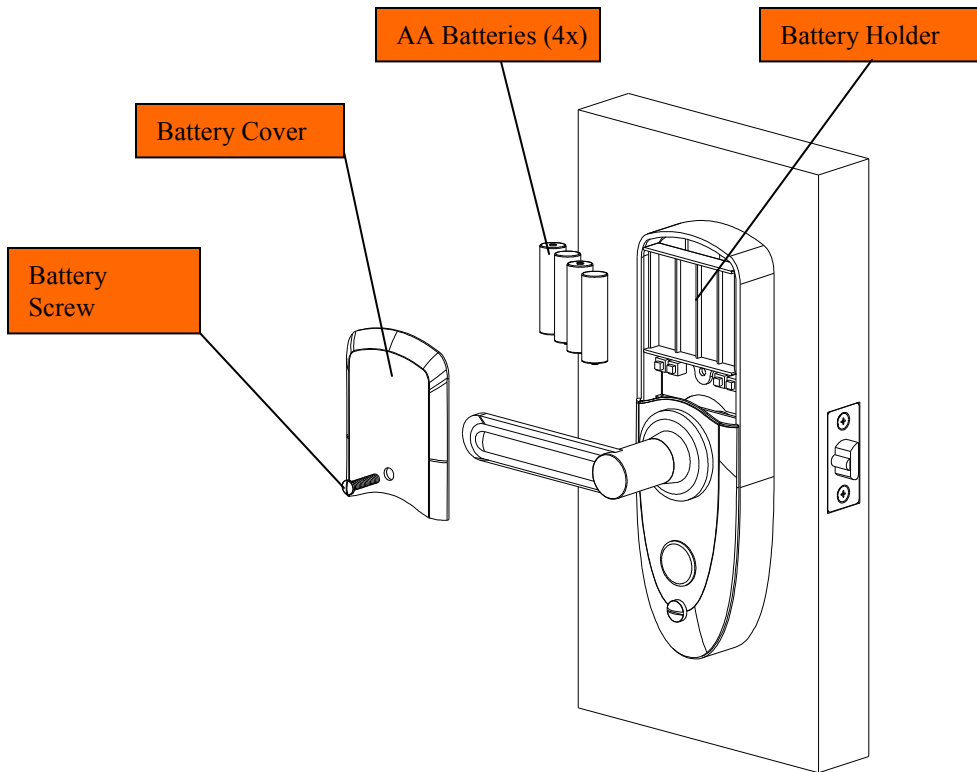

## 2.4) Cautions during installation

- ***Always bring emergency key during installation.***
- Fingerprint access is not allowed without batteries installed.***
- Make sure the connector cables are positioned away from case mounting screw when inserting the screw through the back housing into the threaded mounting post of the front case, to prevent cable damage during installation..
- Make sure the polarity of batteries are placed correctly.
- When making holes in door and door frame, make sure the holes are perpendicular to the door surface.
- Check latch bolt operation by opening and closing the door several times.

## 2.5) Installing External DC Power

### 2.5.1) When to use External DC Power

If the door lock is to be mounted on a high usage door, say greater than 200 openings per day, use of external DC power is recommended, as high frequency use of battery power will shorten battery life due to battery characteristics (the internal resistance of battery will increase).

### 2.5.2) Installing External DC Power to L101

L101 can be powered by external DC power instead of using four batteries. The external power supply must be able to supply 6 Volts DC with 1000mA to the door lock. An UPS is recommended for this application.

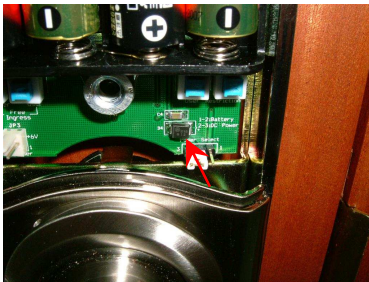

*Power Select jumper set at 1-2  
(uses batteries)*

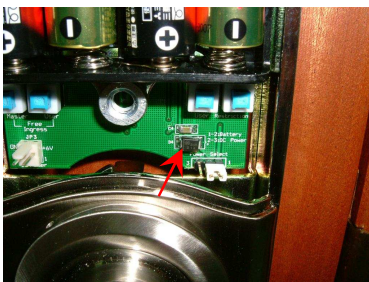

*Power Select jumper set at 2-3  
(Uses external DC)*

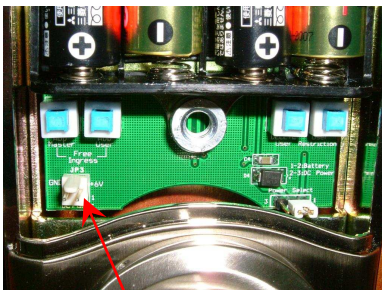

*DC socket JP3*

#### Installation Procedures:

- Use a coin to unscrew the battery cover screw and remove the battery cover.
- Remove any (if installed) AA batteries from the battery compartment.
- Remove the Power Select jumper from 1-2 and set at 2-3.
- Connect the external DC power to socket JP3 with pin 1 = DC +6V, pin 2 = GND.
- Replace battery cover and tighten holding screw.

#### Cautions:

- Make sure the Power Select jumper is set at 2-3 when using external power.
- The battery circuit will be open after setting the jumper.
- If the external DC power fails, the unit will NOT switch to battery operation.

### 2.5.3) Installing External DC Power to L113

L113 can be powered by external DC power instead of using four batteries. The external power supply must be able to supply 6 Volts DC with 1000mA to the door lock. An UPS is recommended for this application.

Installation Procedures:

- Use a coin to unscrew the battery cover screw and remove the battery cover.
- Remove any (if installed) AA batteries from the battery compartment.
- Use a needle-nose pliers to remove the housing of the two wire cable connected to the battery compartment.
- Connect the provided DC power cable with the housing end to the Header on PCBA.
- Wire the cable to the front side of the door lock through the hole at the right of the Header.
- Use a sticker tape to hold the DC power cable on the PCB.
- Connect the DC power cable to the external power source. Connect the Red wire to 6V+ and the Black wire to Ground.
- Replace battery cover and tighten holding screw.

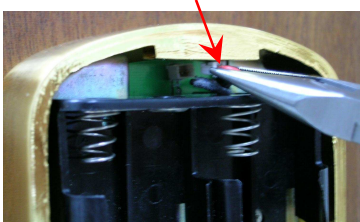

*Remove cable connected to the battery compartment*

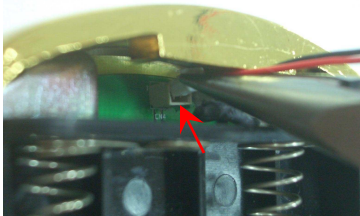

*Connect DC power cable to the header on PCBA*

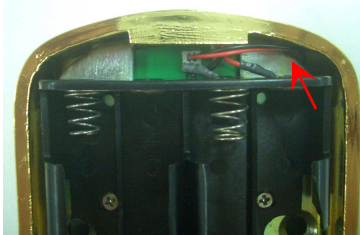

*Wire the cable to the front side of the door lock through the hole at the right side of the Header*

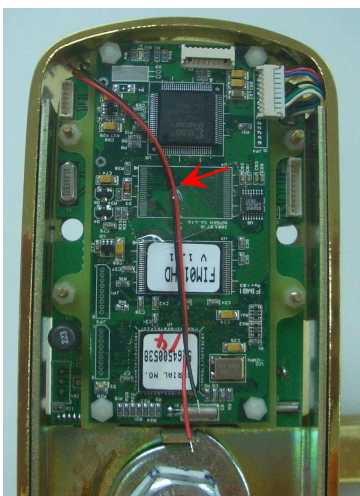

*Hold the DC power cable on the PCBA*

Note: Make sure the connectors are aligned with the Header before pushing them into position to prevent bending of pins, or breakage of socket walls.